

Turning Center Series



— WEBSITE —



— LINE —



— WECHAT —



凱豐機械股份有限公司
KAI FENG MACHINERY CO., LTD.
No. 19, 31st Street, Xitun District,
Taichung Industrial Park, Taichung City, Taiwan 40768
☎+886 4 2359 8133 📠+886 4 2359 8733
🏠www.keepwaycnc.com ✉info@keepwaycnc.com

Agent / Distributor



Product Catalog

KEEP TURNING THE WORLD

Company Profile

About Us	04
History	05
Our Vision	06

Models

KT Series	07
KT Features [Linear]	09
KT-16	11
KT-18	12
KT Features [Linear]	13
KT-200S	15
KT-20LS	16
KT-25S	17
KT-25LS	18
Specification	19
KT Features [Box]	21
KT-200	23
KT-20L	24
KT-25 / 25L	25
KT-30 / 30L	26
Automation Solution	27
Cutter Interference	29
Output & Torque	31
Floor Space	33
Specification	35
KT Features [Turn-Mill Series]	37
KT-20M / LM	41
KT-25M / LM	42
Cutter Interference	43
KT Features [Y-axis Series]	45
KT-20YM / YLM	47
KT-25YM / YLM	48
Output & Torque	49
Floor Space	51
Specification	53

***KEEP
TURNING
THE WORLD***



***KEEP
TURNING
THE WORLD***

“KEEP TURNING THE WORLD”

About Us

KAIFENG MACHINERY CO., LTD. is a leading manufacturer of machine tools with a presence in Taichung, Taiwan and three other offices in the Asia region. To expand our business scope, we established a new production facility in Fujian, China in 2018 to better serve our clients in the Greater China Region.

At KAIFENG MACHINERY, we are dedicated to staying ahead of the curve with our persistent search for new technology and continuous innovation. We strive to be your ideal partner, offering the most potential for successful collaboration.

Background



KAIFENG MACHINERY was founded in 2002 with a shared belief in "Quality, Precision, Stability, Accuracy, and Reliability." We are continuously expanding our sales reach and machining capabilities. Our current product line includes turning centers (CNC lathes) and machining centers with varying specifications.



We strive to enhance our clients' production efficiency by developing advanced equipments, such as multi-axial machinery and automatic loading and unloading systems capable of handling highly complex models.

Certificates

We are committed to the highest standards of product quality and safety. We prioritize aligning our machinery products with strict international standards in our pursuit of excellence. All of our machine products are qualified with CE Safety Certification and hold numerous patents.

Connect us

 Facebook : @keepwaycnc
 YouTube : keepway

 GooglePlus : keepway
 Instagram : keepwaycnc

2002 Establishment of KAIFENG MACHINERY

KAIFENG MACHINERY CO., LTD. was established in 2002 by Chairman Chiu, who had previously been one of the largest machine tool distributors in the local area. His passion for machine tools laid the foundation for the establishment of Kaifeng Machinery, and under his leadership, the company has traversed several decades and continues to progress into more.

2003 Development of Machining Centers

KAIFENG MACHINERY actively engaged in the research and manufacturing of machining centers, with the first vertical machining center officially launched. Simultaneously, the company moved towards the development of a diverse range of machinery.

2005 Development of Turning Centers

Turning Center Development – we established the production line with a focus on machining center products while relentlessly developing the turning center series on the side.

2012 Celebration of 10th Anniversary

Beginning with the production of machining centers, we ventured into the research and manufacturing of turning centers. While the initial focus was on machining centers, the sales volume of turning centers has far surpassed that of machining centers, showcasing the company's remarkable achievements in various machine categories.

2014 Launch of New Turning Centers

The development of new turning center models, KT-16 and KT-18, have been successfully completed. These machines boast a compact floor space while delivering precise machining performance. Their strong advantages in factory layout further enrich the company's product line.

2017 Introduction of Multi-tasking Turning Center

The new multi-functional turn-mill compound machine model, KT-20YM, was officially released as part of the KT series, combines the Y-axis and C-axis functionalities. This integration forms a multi-axis turn-mill compound machine is capable of achieving complex processing, meeting the composite processing demands that are typically challenging for conventional turning centers.

Global Market Coverage



Our Vision

We are continuously striving to become a better partner for our customers by constantly improving ourselves. Our goal is to be the manufacturer that best understands and satisfies our customers' needs, and we achieve this through effective communication and a thorough understanding of their requirements. We believe that a strong partnership between both parties is essential for mutual success.

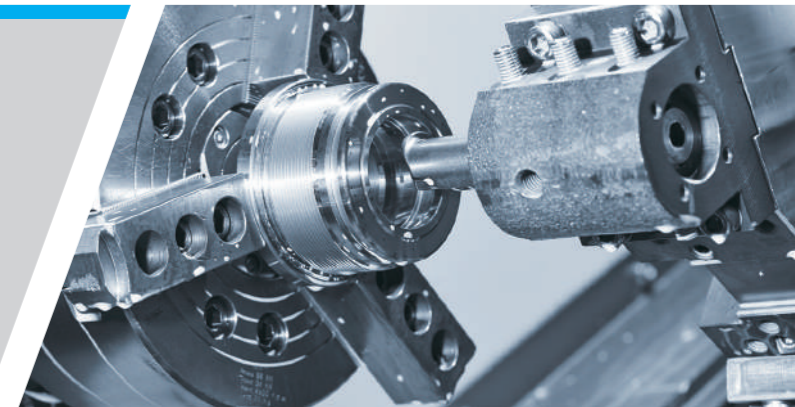

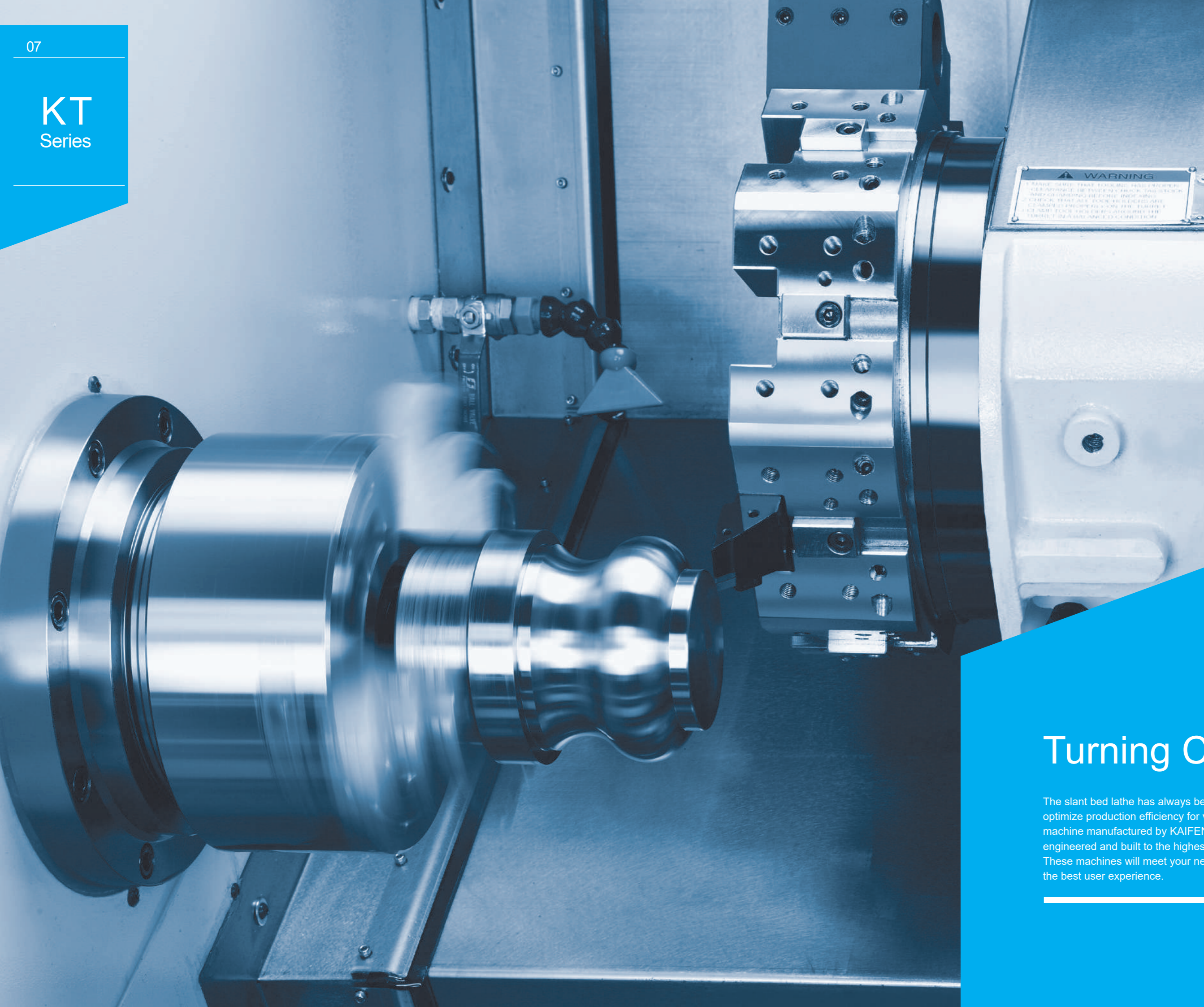

Turning Centers

The slant bed lathe has always been our strength. To optimize production efficiency for various applications, each machine manufactured by KAIFENG MACHINERY is engineered and built to the highest industry standards. These machines will meet your needs and provide you with the best user experience.

Interior Structure

Incorporating a 30° slant wedge saddle design and a robust heavy-duty foundation, we have strategically optimized the overall machine structure's rigidity, specifically focusing on enhancing the stability of the headstock, turret, and tailstock components.

Spindle

The headstocks of all our products features one-piece castings. They are equipped with high-precision bearings from NSK/TNT, renowned for their capacity to withstand heavy bearing loads, delivering exceptional precision and durability performance.

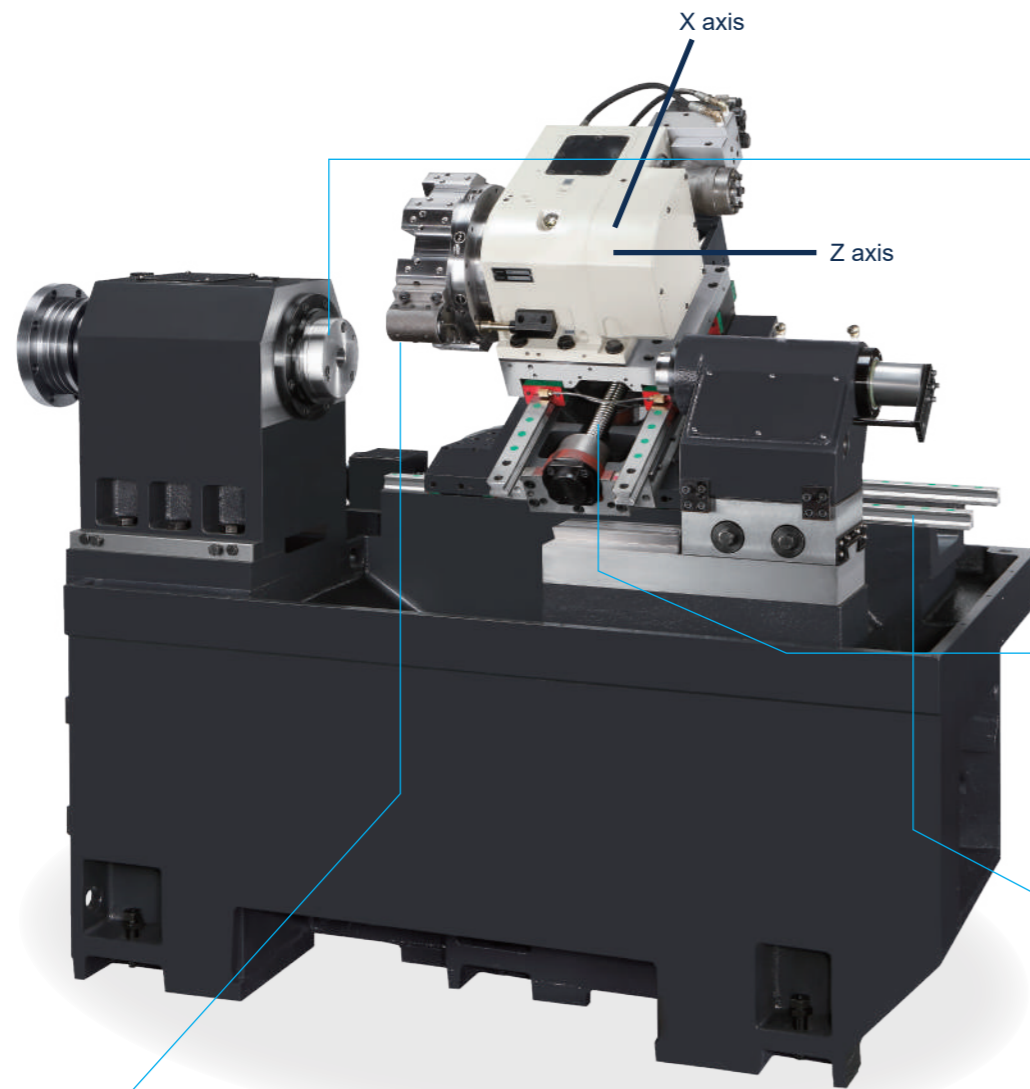

Ball Screw

All the models are equipped with high-class ball screws, ensuring high positioning accuracy. The ball screw pretension design is employed across all axes to effectively minimize the need for backlash compensation in the machine body, resulting in exceptional repeatability and positioning accuracy.

Turret

The interior mechanism utilizes a flat parallel cam, renowned for its high indexing accuracy and rapid tool changing capabilities. The turret disk rotation is driven by an oil pressure motor, offering substantial cutting torque, and enhancing overall performance stability. This design accommodates both heavy and light cutting requirements.

Slideway

The implementation of linear slideways effectively reduces friction while simultaneously offering exceptional positioning accuracy. From an after-sales maintenance perspective, the linear guideway is relatively user-friendly, allowing for straightforward maintenance by simply replacing the sliding blocks and slideway components to restore optimal performance.



KT-16

Specification

ITEM	KT-16
Max turning diameter	260 mm
Max turning length	300 mm
Bar capacity	42 mm
Chuck size	6"
Spindle motor	7.5/11 kw
Spindle speed	5000 rpm
Spindle nose	A2-5
X-axis travel	125+20 mm
Z-axis travel	300 mm
X-axis rapid feed rate	24 m/min
Z-axis rapid feed rate	30 m/min
Rail type	Linear
Tool capacity	8 T
Tailstock travel	200 mm
Floor space (LxWxH)	2790x1647x1713 mm
Machine weight	3300 kg



KT-18

Specification

ITEM	KT-18
Max turning diameter	260 mm
Max turning length	300 mm
Bar capacity	52 mm
Chuck size	8"
Spindle motor	7.5/11 kw
Spindle speed	4500 rpm
Spindle nose	A2-6
X-axis travel	125+20 mm
Z-axis travel	300 mm
X-axis rapid feed rate	24 m/min
Z-axis rapid feed rate	30 m/min
Rail type	Linear
Tool capacity	8 T
Tailstock travel	200 mm
Floor space (LxWxH)	2790x1647x1713 mm
Machine weight	3300 kg

Interior Structure

Incorporating a 30° slant wedge saddle design and a robust heavy-duty foundation, we have strategically optimized the overall machine structure's rigidity, specifically focusing on enhancing the stability of the headstock, turret, and tailstock components.

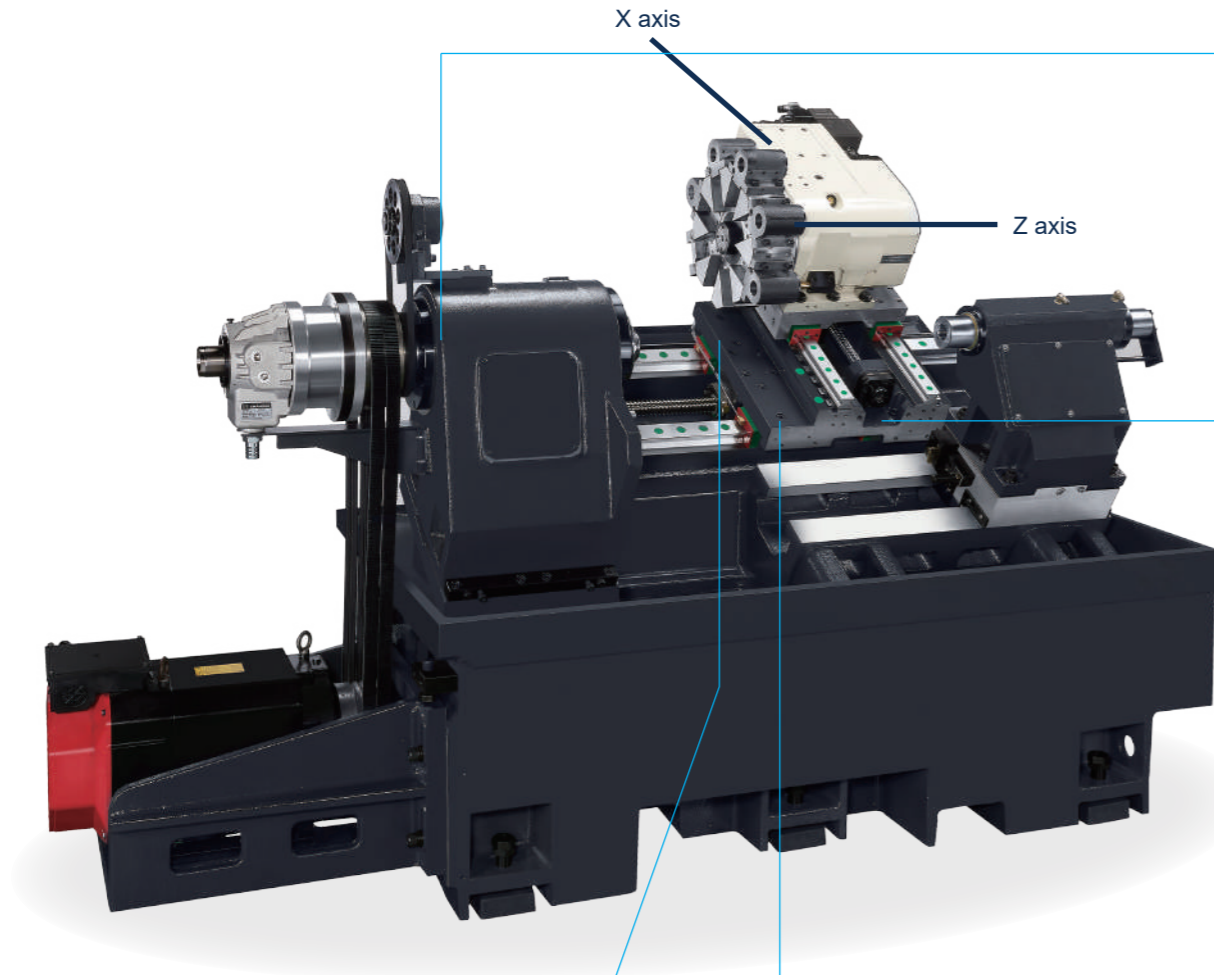

Turret

The interior mechanism utilizes a flat parallel cam is renowned for its high indexing accuracy and rapid tool changing capabilities. The turret disk rotation is driven by an oil pressure motor, offering substantial cutting torque, and enhancing overall performance stability. This design accommodates both heavy and light cutting requirements.

Spindle

The headstocks of all our products features one-piece castings. They are equipped with high-precision bearings from NSK/TNT, renowned for their capacity to withstand heavy bearing loads, delivering exceptional precision and durability performance.

Spindle motor of Fanuc iIP is used for the bigger model, to achieve maximum torque output at low speed.

Ball Screw

All the models are equipped with high-class ball screws, ensuring high positioning accuracy. We employ a ball screw pretension design across all axes to effectively minimize the need for backlash compensation in the machine body. This results in exceptional repeatability and positioning accuracy.

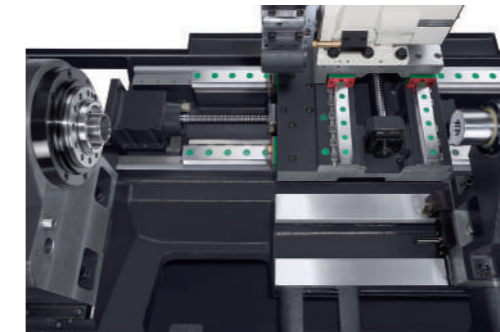

Slide Way

The implementation of linear slideways effectively reduces friction while simultaneously offering exceptional positioning accuracy. From an after-sales maintenance perspective, the linear guideway is relatively user-friendly, allowing for straightforward maintenance by simply replacing the sliding blocks and slideway components to restore optimal performance.



KT-200S

Specification

ITEM	KT-200S
Max turning diameter	360 mm
Max turning length	500 mm
Bar capacity	52 mm (OPT: 65mm)
Chuck size	8"
Spindle motor	11/15 kw
Spindle speed	4500 rpm
Spindle nose	A2-6
X-axis travel	180+20 mm
Z-axis travel	500 mm
X-axis rapid feed rate	24 m/min
Z-axis rapid feed rate	24 m/min
Rail type	Linear
Tool capacity	8 T
Tailstock travel	425 mm
Floor space (LxWxH)	3318x1675x1727 mm
Machine weight	4000 kg



KT-20LS

Specification

ITEM	KT-20LS
Max turning diameter	360 mm
Max turning length	750 mm
Bar capacity	52 mm (OPT: 65mm)
Chuck size	8"
Spindle motor	11/15 kw
Spindle speed	4500 rpm
Spindle nose	A2-6
X-axis travel	180+20 mm
Z-axis travel	750 mm
X-axis rapid feed rate	24 m/min
Z-axis rapid feed rate	24 m/min
Rail type	Linear
Tool capacity	8 T
Tailstock travel	675 mm
Floor space (LxWxH)	4070x1705x1844 mm
Machine weight	5000 kg



KT-25S

Specification

ITEM	KT-25S
Max turning diameter	360 mm
Max turning length	500 mm
Bar capacity	75 mm
Chuck size	10"
Spindle motor	15/18.5 kw
Spindle speed	3500 rpm
Spindle nose	A2-8
X-axis travel	180+30 mm
Z-axis travel	500 mm
X-axis rapid feed rate	20 m/min
Z-axis rapid feed rate	20 m/min
Rail type	Linear
Tool capacity	10 T
Tailstock travel	425 mm
Floor space (LxWxH)	3508x1658x1854 mm
Machine weight	4500 kg



KT-25LS

Specification

ITEM	KT-25LS
Max turning diameter	360 mm
Max turning length	750 mm
Bar capacity	75 mm
Chuck size	10"
Spindle motor	15/18.5 kw
Spindle speed	3500 rpm
Spindle nose	A2-8
X-axis travel	180+30 mm
Z-axis travel	750 mm
X-axis rapid feed rate	20 m/min
Z-axis rapid feed rate	20 m/min
Rail type	Linear
Tool capacity	10 T
Tailstock travel	675 mm
Floor space (LxWxH)	4070x1705x1844 mm
Machine weight	5200 kg

ITEM	UNIT	KT-16	KT-18	KT-200S	KT-20LS	KT-25S	KT-25LS
Bed swing diameter	mm	450	450	530	530	530	530
Saddle swing diameter	mm	280	280	380	380	380	380
Maximum turning diameter	mm	260	260	360	360	360	360
Maximum turning length	mm	300	300	500	750	500	750
Bar capacity	mm	42	52	52 (OPT: 65)	52 (OPT: 65)	75	75
Power chuck diameter	inch	6	8	8	8	10	10
Spindle motor power	kw	7.5/11	7.5/11	11/15	11/15	15/18.5	15/18.5
Spindle speed	rpm	5000	5000	4500	4500	3500	3500
Spindle nose taper	inch	A2-5	A2-6	A2-6	A2-6	A2-8	A2-8
Spindle bearing diameter	mm	90	100	100 (110)	100 (110)	120	120
Spindle taper	-	1/20	1/20	1/20	1/20	1/20	1/20
X/Z-axis servo motor	kw	1.2/1.2	1.2/1.2	3/3	3/3	3/3	3/3
X-axis travel	mm	125+20	125+20	180+20	180+20	180+30	180+30
Z-axis travel	mm	300	300	500	750	500	750
X-axis rapid feed rate	m/min	24	24	24	24	20	20
Z-axis rapid feed rate	m/min	30	30	24	24	20	20
Rail type	-	Linear	Linear	Linear	Linear	Linear	Linear
X/Z-axis ballscrew/pitch	mm	32/32 (P8/P10)	32/32 (P8/P10)	32/36 (P8/P10)	32/36 (P8/P10)	32/36 (P8/P10)	32/36 (P8/P10)
X/Z-axis slideway width	mm	35/35	35/35	35/45	35/45	35/45	35/45
Turret driven type	-	Hydraulic	Hydraulic	Hydraulic	Hydraulic	Hydraulic	Hydraulic
Tool capacity	T	8	8	8	8	10	10
OD tool shank size	mm	25	25	25	25	25	25
ID tool shank size	mm	32	32	32	32	40	40
Tailstock travel positioning	-	Hydraulic	Hydraulic	Hydraulic	Hydraulic	Hydraulic	Hydraulic
Tailstock quill taper diameter	mm	70	70	70	70	85	85
Tailstock quill travel	mm	80	80	110	110	150	150
Tailstock base travel	mm	200	200	425	675	425	675
Quill taper size	MT	MT#4	MT#4	MT#4	MT#4	MT#5	MT#5
Hydraulic tank capacity	liter	30	30	60	60	60	60
Coolant tank capacity	liter	145	145	150	310	150	310
Floor space (LxWxH)	mm	2790x1647x1713	2790x1647x1713	3318x1675x1727	4070x1705x1844	3508x1658x1854	4070x1705x1844
Machine weight	kg	3300	3300	4000	5000	4500	5200

Standard Accessories

ITEM	
FANUC 0i-TF Plus controller with 10.4" color LCD display	Coolant pump (5kg/cm ²)
Graphic function (Manual Guide 0i)	Coolant tank
Part program storage size (2MB)	LED work light
Registered program (1000)	Three color warning work light
Automatic data backup	Heat exchanger for electric cabinet
Hydraulic hollow cylinder for chuck	Advanced auto lubrication system
Hydraulic 3-jaws chuck	Belt type chip conveyor and chip cart (right discharge)
Standard soft jaws	Foot switch for chuck operation
Hydraulic power supply unit	Fully enclosed guarding
Turret (tool holder and sleeve package)	Foundation leveling pads
Facing tool holder Φ25mm : 1	Maintenance tool kit
Boring bar holder Φ32(40)mm : 5	Operation & maintenance manuals
Boring bar socket Φ32(40)mm (8/25mm) : 1	2-years warranty on controller
Boring bar socket Φ32(40)mm (10/12/16/20mm) : 2	1-year warranty on machine parts
Hydraulic tailstock	

Optional Accessories

ITEM	
Fanuc 0i-TF Plus Alpha (α22) spindle motor	Chuck air blow
Fanuc 0i-TF Plus Alpha (α30) spindle motor	Oil mist collector
Mitsubishi controller	Oil and water separator
Siemens controller	High pressure coolant pump
Syntec controller	Auto door
Hollow 2-jaw hydraulic chuck	Auto parts catcher
Hollow 3-jaw hydraulic chuck	Work-piece transport conveyor
Hollow 4-jaw hydraulic chuck	Bar feeder
Collet chuck	Auto parts loader/unloader (gantry style)
Programmable quill hydraulic tailstock	Door close start switch
Tailstock quill travel extension	A/C cooling system for electrical cabinet
Live center	Counter
Forming coil	Exterior control box
Keep-off rod	Regulator transformer
Tool presetter	

Interior Structure

The one-piece casting slant bed design significantly enhances structural rigidity. Through the incorporation of a 30° slant bed design and a robust heavy-duty foundation, we have systematically optimized the overall machine structure's rigidity, specifically targeting improvements in the headstock, turret, and tailstock components.

Spindle

The headstocks of all our products features one-piece castings. We install high-precision bearings from NSK/TNT, renowned for their capacity to withstand heavy bearing loads, delivering exceptional precision and durability performance.

Hand-Scraping Technique

The hand-scraping procedure is applied to contacting surfaces throughout all guide way slides, headstock, turret, and tailstock. This ensures ultimate assembly precision, structural rigidity, and balanced loading distribution.

Ball Screw

All the models are equipped with high-class ball screws, ensuring high positioning accuracy. We employ a ball screw pretension design across all axes to effectively minimize the need for backlash compensation in the machine body. This results in exceptional repeatability and positioning accuracy.

Slideway

The TURCITE-B material is applied on both the X and Z slideways, firmly adhering it to prevent lubricant counter-flow and to facilitate seamless transmission.

Turret

The interior mechanism utilizes a flat parallel cam is renowned for its high indexing accuracy and rapid tool changing capabilities. The turret disk rotation is driven by an oil pressure motor, offering substantial cutting torque, and enhancing overall performance stability. This design accommodates both heavy and light cutting requirements.

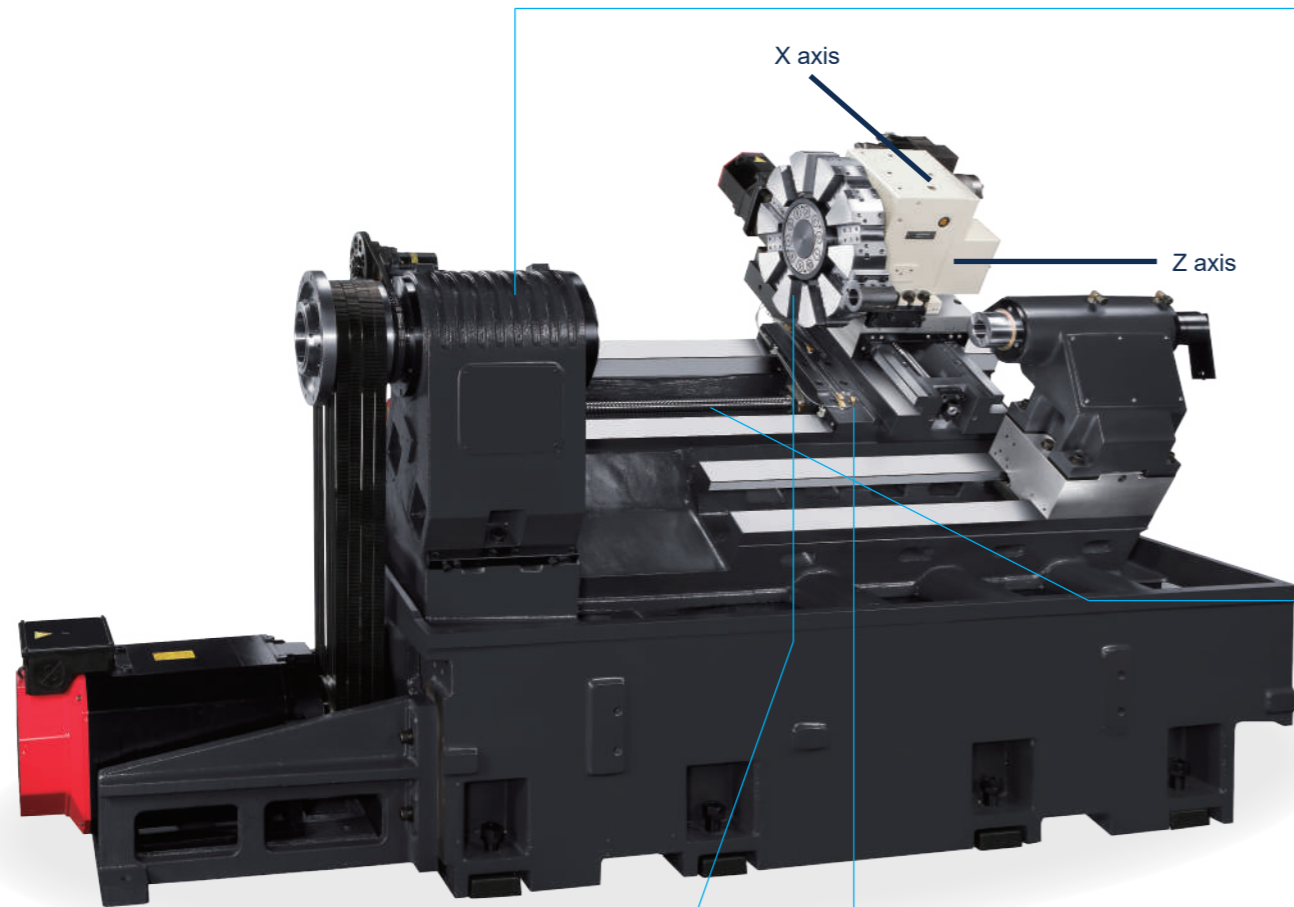



KT-200

Specification

ITEM	KT-200
Max turning diameter	360 mm
Max turning length	500 mm
Bar capacity	52 mm
Chuck size	8"
Spindle motor	11/15 kw
Spindle speed	4500 rpm
Spindle nose	A2-6
X-axis travel	180+20 mm
Z-axis travel	500 mm
X-axis rapid feed rate	24 m/min
Z-axis rapid feed rate	24 m/min
Rail type	Box
Tool capacity	8 T
Tailstock travel	425 mm
Floor space (LxWxH)	3318x1675x1727 mm
Machine weight	4000 kg



KT-20L

Specification

ITEM	KT-20L
Max turning diameter	360 mm
Max turning length	750 mm
Bar capacity	52 mm
Chuck size	8"
Spindle motor	11/15 kw
Spindle speed	4500 rpm
Spindle nose	A2-6
X-axis travel	180+20 mm
Z-axis travel	750 mm
X-axis rapid feed rate	24 m/min
Z-axis rapid feed rate	24 m/min
Rail type	Box
Tool capacity	8 T
Tailstock travel	675 mm
Floor space (LxWxH)	4070x1705x1844 mm
Machine weight	5000 kg



KT-25 / 25L

Specification

ITEM	KT-25	KT-25L
Max turning diameter	360 mm	360 mm
Max turning length	500 mm	750 mm
Bar capacity	75 mm	75 mm
Chuck size	10"	10"
Spindle motor	15/18.5 kw	15/18.5 kw
Spindle speed	3500 rpm	3500 rpm
Spindle nose	A2-8	A2-8
X-axis travel	180+30 mm	180+30 mm
Z-axis travel	500 mm	750 mm
X-axis rapid feed rate	20 m/min	20 m/min
Z-axis rapid feed rate	20 m/min	20 m/min
Rail type	Box	Box
Tool capacity	10 T	10 T
Tailstock travel	425 mm	675 mm
Floor space (LxWxH)	3508x1658x1854 mm	4070x1705x1844 mm
Machine weight	4500 kg	5200 kg



KT-30 / 30L

Specification

ITEM	KT-30	KT-30L
Max turning diameter	580 mm	580 mm
Max turning length	750 mm	1200 mm
Bar capacity	85 mm	85 mm
Chuck size	12"	12"
Spindle motor	15/18.5 kw	15/18.5 kw
Spindle speed	3000 rpm	3000 rpm
Spindle nose	A2-8	A2-8
X-axis travel	290+25 mm	290+25 mm
Z-axis travel	750 mm	1200 mm
X-axis rapid feed rate	20 m/min	20 m/min
Z-axis rapid feed rate	20 m/min	20 m/min
Rail type	Box	Box
Tool capacity	10 T	10 T
Tailstock travel	675 mm	1125 mm
Floor space (LxWxH)	4307x1770x1942 mm	4786x1932x1941 mm
Machine weight	5700 kg	5900 kg



Specification

ITEM	UNIT	KAR-800	KAR-1000	KAR-1200
X-axis travel	mm	1,500	1,800	2,000
Z-axis travel	mm	800	800	800
X-axis rapid feed rate	m/min	90	90	90
Z-axis rapid feed rate	m/min	75	75	75
C-axis rapid feed rate	°/sec	450	450	450
Positioning accuracy	mm	+/-0.05	+/-0.05	+/-0.05
Servo system	-	Syntec	Syntec	Syntec
Load capacity	kg	3	3	3
Pallet number	pcs	6	6	6
Pallet size	mm	360x300	360x300	360x300
Pallet load capacity	kg	30	30	30
Robot weight	kg	300	300	300



KT-16

Max turning diameter 260 mm
 Max turning length 300 mm
 Chuck size 6"
 Tool capacity 8T
 OD tool shank size 25 mm

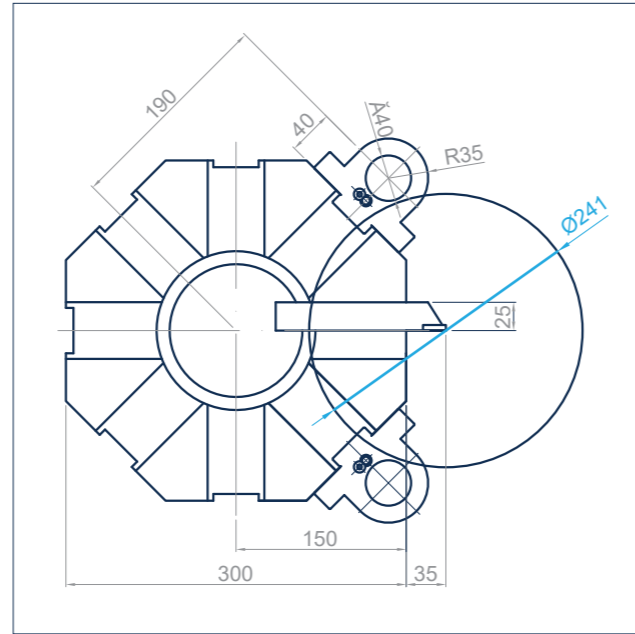

KT-18

Max turning diameter 260 mm
 Max turning length 300 mm
 Chuck size 8"
 Tool capacity 8T
 OD tool shank size 25 mm

KT-200

Max turning diameter 360 mm
 Max turning length 500 mm
 Chuck size 8"
 Tool capacity 8T
 OD tool shank size 25 mm

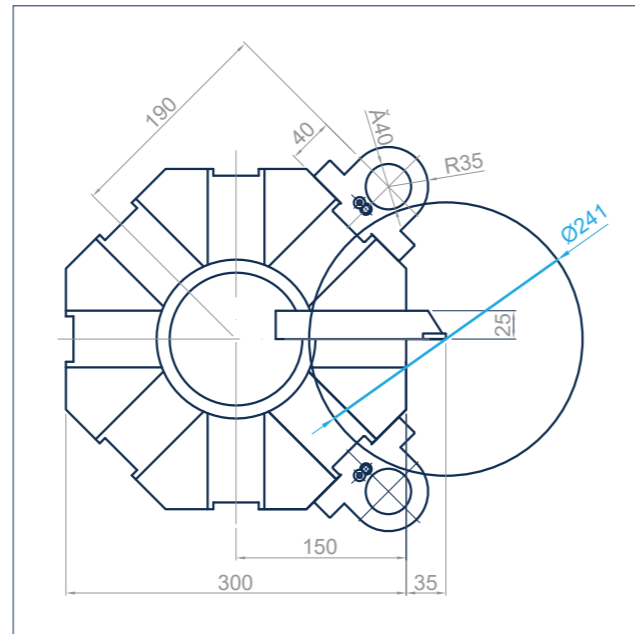

KT-20L

Max turning diameter 360 mm
 Max turning length 750 mm
 Chuck size 8"
 Tool capacity 8T
 OD tool shank size 25 mm

KT-25 / 25L

Max turning diameter 360 mm 360 mm
 Max turning length 500 mm 750 mm
 Chuck size 10" 10"
 Tool capacity 10T 10T
 OD tool shank size 25 mm 25 mm

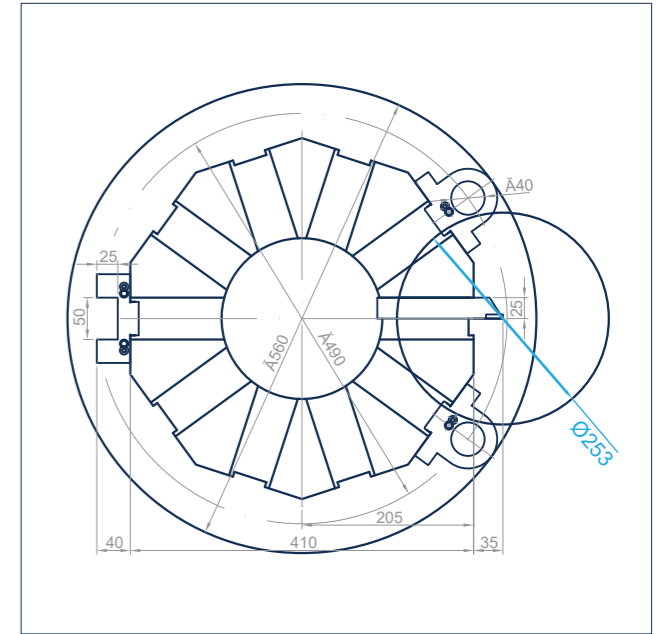

KT-30 / 30L

Max turning diameter 580 mm 580 mm
 Max turning length 750 mm 1200 mm
 Chuck size 12" 12"
 Tool capacity 10T 10T
 OD tool shank size 25 mm 25 mm

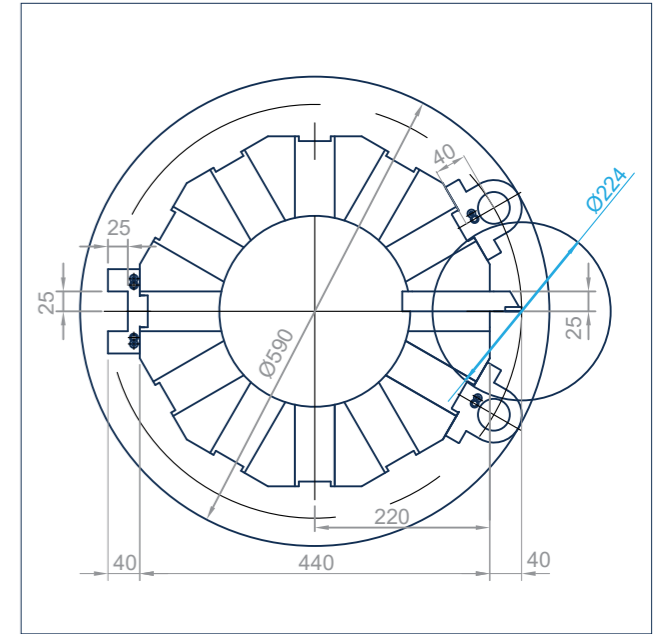

KT-200

KT-20L

α22

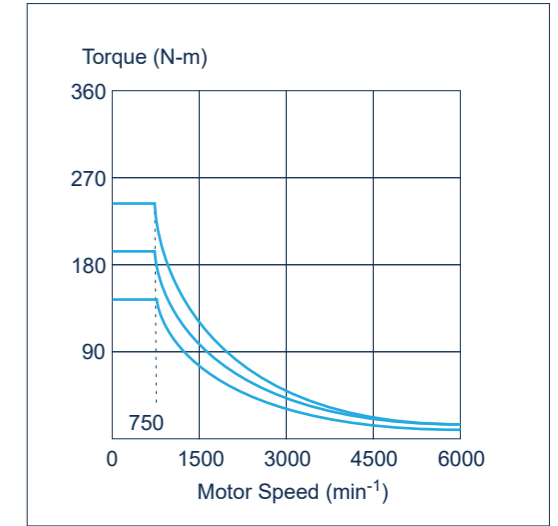
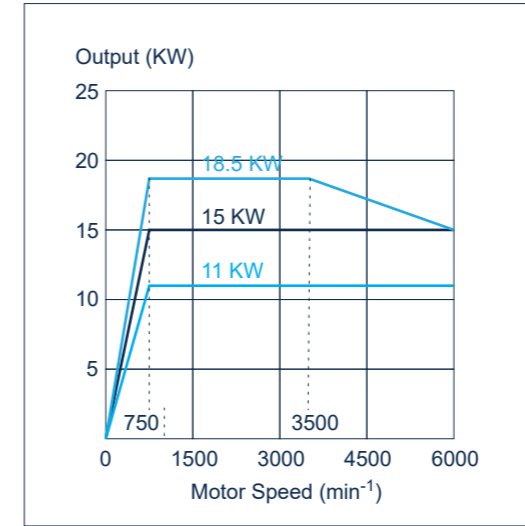

KT-16

KT-18

β8

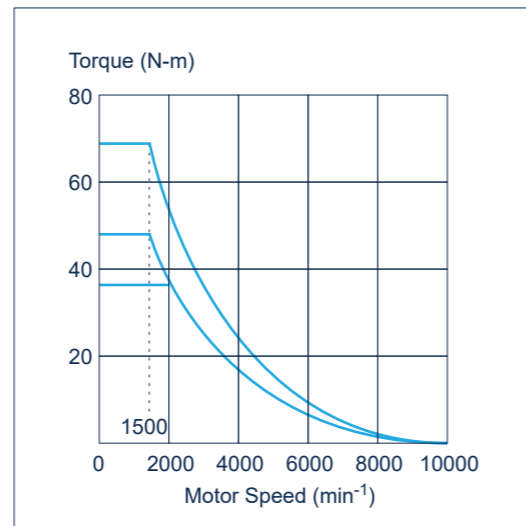
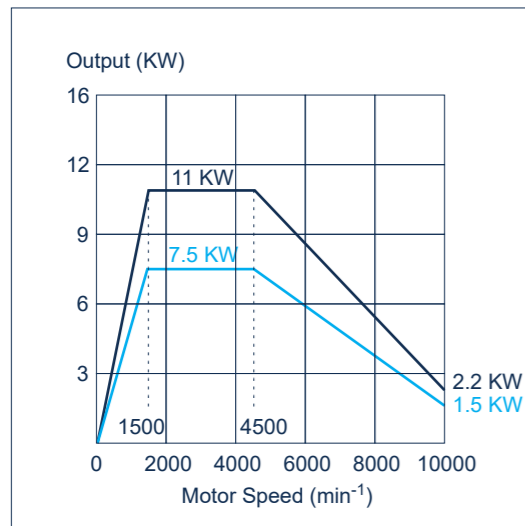

KT-25 / 25L

β30

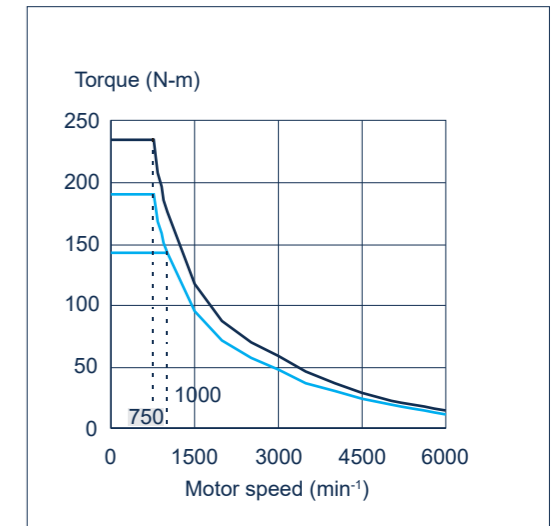
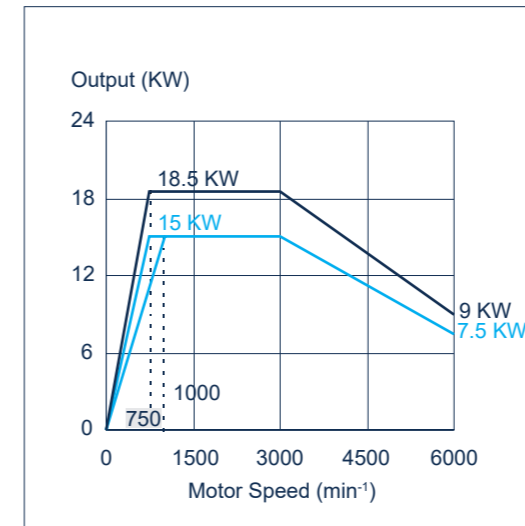

KT-200

KT-20L

β22

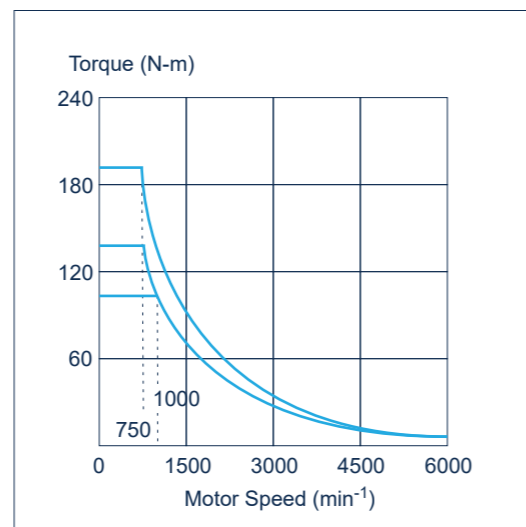
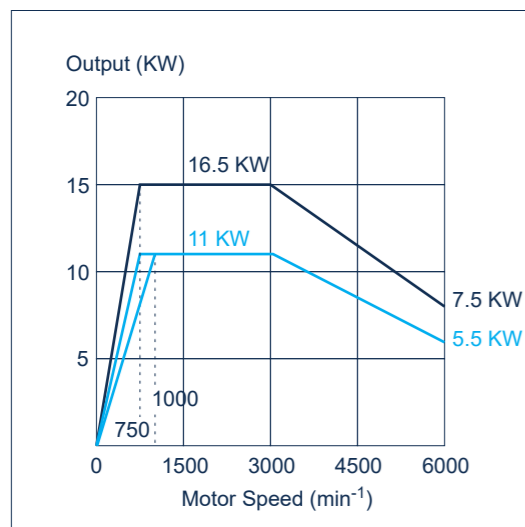

KT-30 / 30L

α30

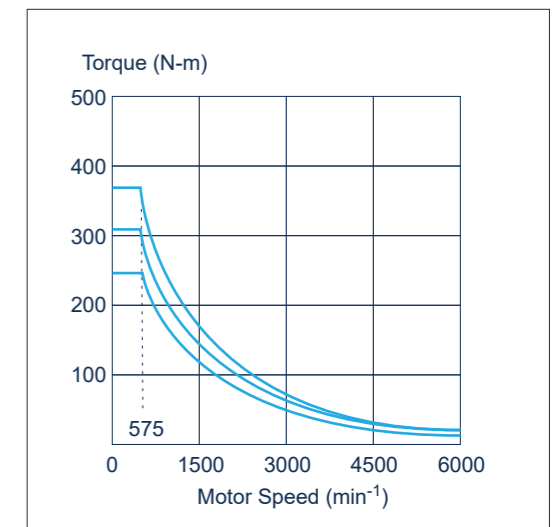
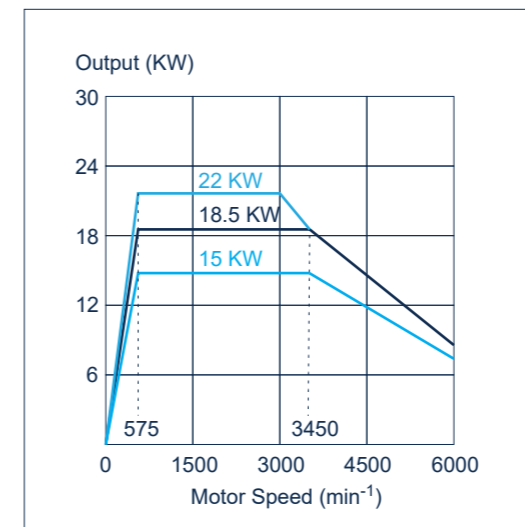

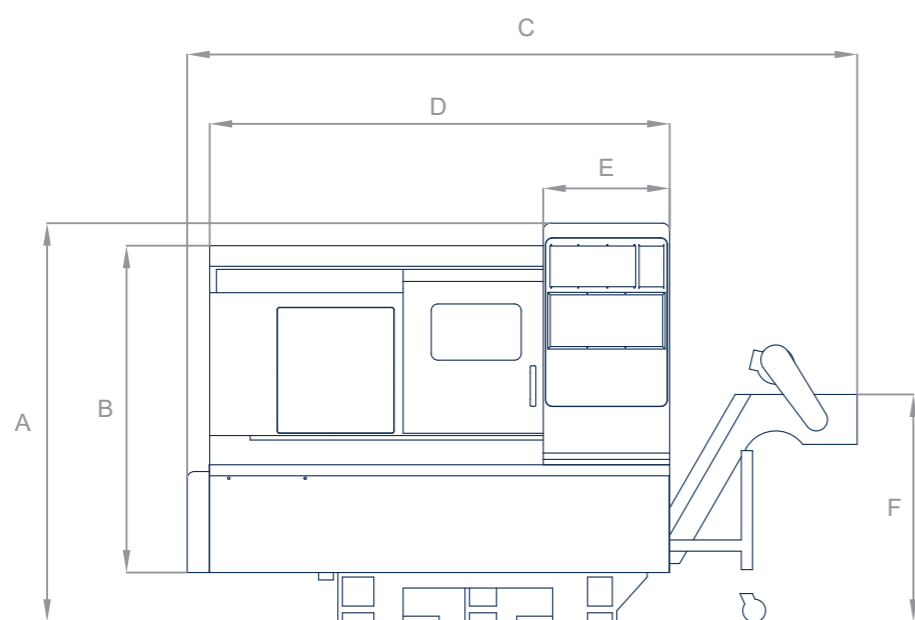

Front

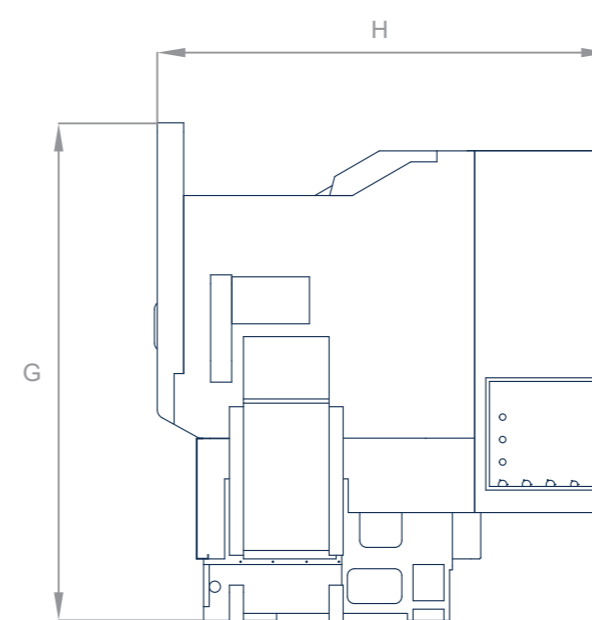

Side

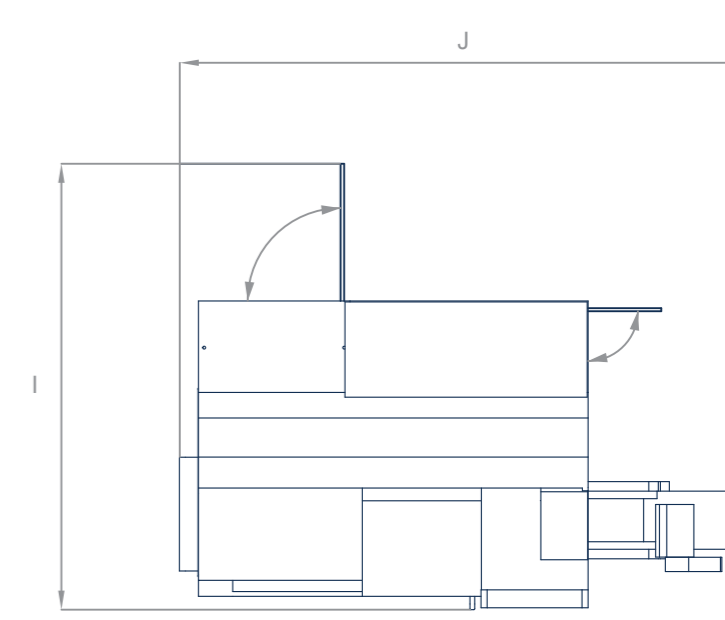

Top

Specification

ITEM	KT-16	KT-18	KT-200	KT-20L
A	1713 mm	1713 mm	1727 mm	1844 mm
B	1371 mm	1371 mm	1515 mm	1655 mm
C	2790 mm	2790 mm	3318 mm	4070 mm
D	1777 mm	1777 mm	1980 mm	2897 mm
E	558 mm	558 mm	562 mm	560 mm
F	989 mm	989 mm	1009 mm	1113 mm
G	1713 mm	1713 mm	1727 mm	1844 mm
H	1647 mm	1647 mm	1675 mm	1705 mm
I	2236 mm	2236 mm	2350 mm	2433 mm
J	2650 mm	2650 mm	3318 mm	4070 mm

Specification

ITEM	KT-25	KT-25L	KT-25L-1200	KT-30	KT-30L-1200
A	1854 mm	1844 mm	1941 mm	1942 mm	1941 mm
B	1145 mm	1655 mm	1804 mm	1745 mm	1804 mm
C	3508 mm	4070 mm	4786 mm	4307 mm	4786 mm
D	2500 mm	2897 mm	3912 mm	2897 mm	3912 mm
E	620 mm	560 mm	590 mm	560 mm	590 mm
F	1012 mm	1113 mm	874 mm	1770 mm	874 mm
G	1854 mm	1844 mm	1941 mm	1942 mm	1941 mm
H	1658 mm	1705 mm	1932 mm	1770 mm	1932 mm
I	2366 mm	2433 mm	2660 mm	2499 mm	2660 mm
J	3508 mm	4070 mm	4786 mm	4308 mm	4786 mm



KAIFENG MACHINERY CO., LTD. © RESERVES ALL THE RIGHTS TO AMEND ANY OF THE SPECIFICATION WITHOUT NOTICE.

ITEM	UNIT	KT-200	KT-20L	KT-25	KT-25L	KT-25L-1200	KT-25L-1600	KT-30	KT-30L-1200	KT-30L-1600
Bed swing diameter	mm	530	530	530	530	530	530	600	600	600
Saddle swing diameter	mm	380	380	380	380	380	380	400	400	400
Maximum turning diameter	mm	360	360	360	360	360	360	580	580	580
Maximum turning length	mm	500	750	500	750	1200	1600	750	1200	1600
Bar capacity	mm	52 (OPT: 65)	52 (OPT: 65)	75	75	75	75	85	85	85
Power chuck diameter	inch	8	8	10	10	10	10	12	12	12
Spindle motor power	kw	11/15	11/15	15/18.5	15/18.5	15/18.5	15/18.5	15/18.5	15/18.5	15/18.5
Spindle speed	rpm	4500	4500	3500	3500	3500	3500	3000	3000	3000
Spindle nose taper	inch	A2-6	A2-6	A2-8	A2-8	A2-8	A2-8	A2-8	A2-8	A2-8
Spindle bearing diameter	mm	100 (110)	100 (110)	120	120	120	120	140	140	140
Spindle taper	-	1/20	1/20	1/20	1/20	1/20	1/20	1/20	1/20	1/20
X/Z-axis servo motor	kw	3/3	3/3	3/3	3/3	3/3	3/3	3/3	3/3	3/3
X-axis travel	mm	180+20	180+20	180+30	180+30	180+30	180+30	290+25	290+25	290+25
Z-axis travel	mm	500	750	500	750	1200	1600	750	1200	1600
X-axis rapid feed rate	m/min	24	24	20	20	20	20	20	20	20
Z-axis rapid feed rate	m/min	24	24	20	20	20	20	20	20	20
Slide way type	-	Box	Box	Box	Box	Box	Box	Box	Box	Box
X/Z-axis ballscrew/pitch	mm	32/36 (P8/P10)	32/36 (P8/P10)	32/36 (P8/P10)	32/36 (P8/P10)	32/36 (P8/P10)	32/36 (P8/P10)	32/36 (P10/P10)	32/36 (P10/P10)	32/36 (P8/P10)
X/Z-axis slideway width	mm	50/50/70/80	50/50/70/80	50/50/70/80	50/50/70/80	50/50/70/80	50/50/70/80	58/58//70/80	58/58//70/80	50/50/70/80
Turret driven type	-	Hydraulic	Hydraulic	Hydraulic	Hydraulic	Hydraulic	Hydraulic	Hydraulic	Hydraulic	Hydraulic
Tool capacity	station	8	8	10	10	10	10	10	10	10
OD tool shank size	mm	25	25	25	25	25	25	25	25	25
ID tool shank size	mm	32	32	40	40	40	40	40	40	40
Tailstock travel positioning	-	Hydraulic	Hydraulic	Hydraulic	Hydraulic	Hydraulic	Hydraulic	Hydraulic	Hydraulic	Hydraulic
Tailstock quill taper diameter	mm	70	70	85	85	85	85	85	85	85
Tailstock quill travel	mm	110	110	150	150	150	150	150	150	150
Tailstock base travel	mm	425	675	425	675	1125	1525	675	1125	1525
Quill taper size	MT	MT#4	MT#4	MT#5	MT#5	MT#5	MT#5	MT#5	MT#5	MT#5
Hydraulic tank capacity	liter	60	60	60	60	60	60	60	60	60
Coolant tank capacity	liter	150	310	150	310	510	710	310	510	710
Floor space (LxWxH)	mm	3318x1675x1727	4070x1705x1844	3508x1658x1854	4070x1705x1844	4786x1932x1941	TBC	4307x1770x1942	4786x1932x1941	TBC
Machine weight	kg	4000	5000	4500	5200	5400	8000	5700	5900	8500

Standard Accessories

ITEM	
Fanuc controller with LCD display	Coolant pump (5kg/cm ²)
Part program storage size (2MB)	Roll out coolant tank
Registered program (1000)	LED work light
Automatic data backup	Three color warning work light
Hydraulic hollow cylinder for chuck	Heat exchanger for electric cabinet
Hydraulic 3-jaws chuck	Advanced auto lubrication system
Standard soft jaws	Belt type chip conveyor and chip cart (right discharge)
Hydraulic power supply unit	Foot switch for chuck operation
Turret (tool holder and sleeve package)	Fully enclosed guarding
Facing tool holder Φ25mm: 1 sets	Foundation leveling pads
Boring bar holder Φ32(40)mm: 5 sets	Maintenance tool kit
Boring bar socket Φ32(40)mm (8/25mm): 1 set	Operation & maintenance manuals
Boring bar socket Φ32(40)mm (10/12/16/20mm): 2 sets	2-years warranty on controller
Hydraulic tailstock	1-year warranty on machine parts

Optional Accessories

ITEM	
Fanuc 0i-TF Plus Alpha (α22) spindle motor	Chuck air blow
Fanuc 0i-TF Plus Alpha (α30) spindle motor	Oil mist collector
Mitsubishi controller	Oil and water seperator
Siemens controller	High pressure coolant pump
Syntec controller	Auto door
Hollow 2-jaw hydraulic chuck	Auto parts catcher
Hollow 3-jaw hydraulic chuck	Work-piece transport conveyor
Hollow 4-jaw hydraulic chuck	Bar feeder
Collet chuck	Auto parts loader/unloader (gantry style)
Programmable quill hydraulic tailstock	Door close start switch
Tailstock quill travel extension	A/C cooling system for electrical cabinet
Live center	Counter
Forming coil	Exterior control box
Keep-off rod	Regulator transformer
Tool presetter	

Turn-Mill Centers

The KT turning center series, with spindle C-axis control and a power turret, combines cutting, machining, and drilling functions in one step. This not only greatly reduces production time but also avoids any production errors that may occur when spreading the process across different machines.

Interior Structure

The one-piece casting slant bed design significantly enhances structural rigidity. Through the incorporation of a 30° slant bed design and a robust heavy-duty foundation, we have systematically optimized the overall machine structure's rigidity, specifically targeting improvements in the headstock, turret, and tailstock components.

Spindle

The headstocks of all our products features one-piece castings. We install high-precision bearings from NSK/TNT, renowned for their capacity to withstand heavy bearing loads, delivering exceptional precision and durability performance.

KT turning center series with spindle C-axis control and power turret combine the cutting, machining and drilling into one process. It not only greatly reduces the production time but eliminates the production errors created by having separate processes.

Hand-Scraping Technique

The hand-scraping procedure is applied to contacting surfaces throughout all guide way slides, headstock, turret, and tailstock. This ensures ultimate assembly precision, structural rigidity, and balanced loading distribution.

Ball Screw

All the models are equipped with high-class ball screws, ensuring high positioning accuracy. We employ a ball screw pretension design across all axes to effectively minimize the need for backlash compensation in the machine body. This results in exceptional repeatability and positioning accuracy.

Slideway

The TURCITE-B material is applied on both the X and Z slideways, firmly adhering it to prevent lubricant counter-flow and to facilitate seamless transmission. This ensures the consistent attainment of production accuracy requirements.

Power Turret

The turret is suitable for use on high-capacity turning machines for both forward and equipollent reverse machining. It is equipped with all the features and functions of modern high-performance and high-capacity tool turrets. Its robust design and short switching times make it very well suited for heavy-duty use in series manufacturing.

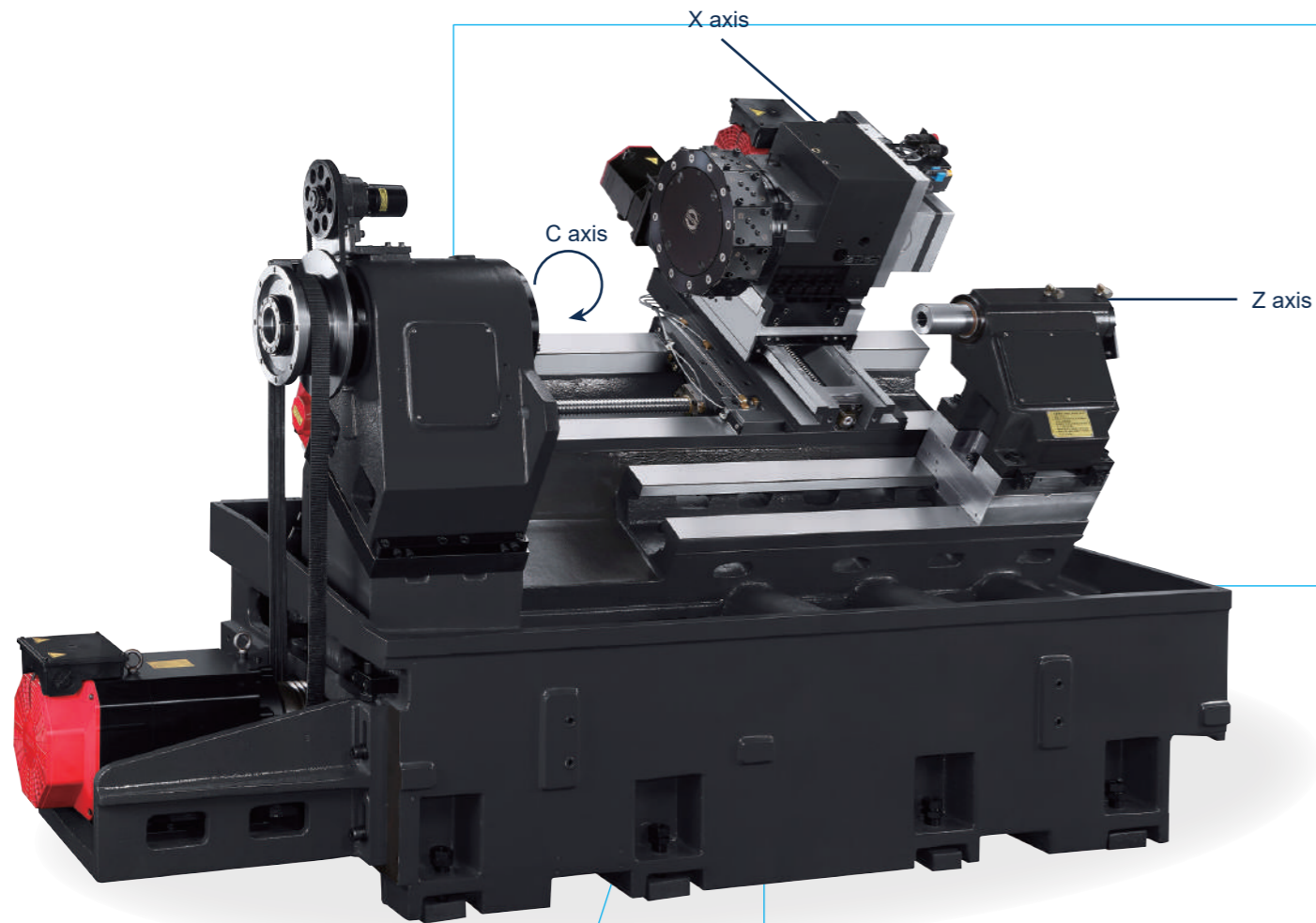



KT-20M / LM

Specification

ITEM	KT-20M	KT-20LM
Max turning diameter	360 mm	360 mm
Max turning length	450 mm	700 mm
Bar capacity	52 mm	52 mm
Chuck size	8"	8"
Spindle motor	11/15 kw	11/15 kw
Spindle speed	4500 rpm	4500 rpm
Spindle nose	A2-6	A2-6
X-axis travel	180+20 mm	180+20 mm
Z-axis travel	450 mm	700 mm
X-axis rapid feed rate	24 m/min	24 m/min
Z-axis rapid feed rate	24 m/min	24 m/min
Rail type	Box	Box
Tool capacity	VDI-40 12T	VDI-40 12T
Tailstock travel	400 mm	650 mm
Floor space (LxWxH)	3510x1848x1867 mm	3838x1660x2150 mm
Machine weight	4500 kg	5200 kg



KT-25M / LM

Specification

ITEM	KT-25M	KT-25LM
Max turning diameter	360 mm	360 mm
Max turning length	450 mm	700 mm
Bar capacity	75 mm	75 mm
Chuck size	10"	10"
Spindle motor	15/18.5 kw	15/18.5 kw
Spindle speed	3500 rpm	3500 rpm
Spindle nose	A2-8	A2-8
X-axis travel	180+30 mm	180+30 mm
Z-axis travel	450 mm	700 mm
X-axis rapid feed rate	20 m/min	20 m/min
Z-axis rapid feed rate	20 m/min	20 m/min
Rail type	Box	Box
Tool capacity	VDI-40 12T	VDI-40 12T
Tailstock travel	400 mm	650 mm
Floor space (LxWxH)	3350x1848x1867 mm	4070x1705x1844 mm
Machine weight	4700 kg	5200 kg

KT-20M

Max turning diameter 360 mm
 Max turning length 450 mm
 Chuck size 8"
 Tool capacity 12T

KT-20LM

Max turning diameter 360 mm
 Max turning length 700 mm
 Chuck size 8"
 Tool capacity 12T

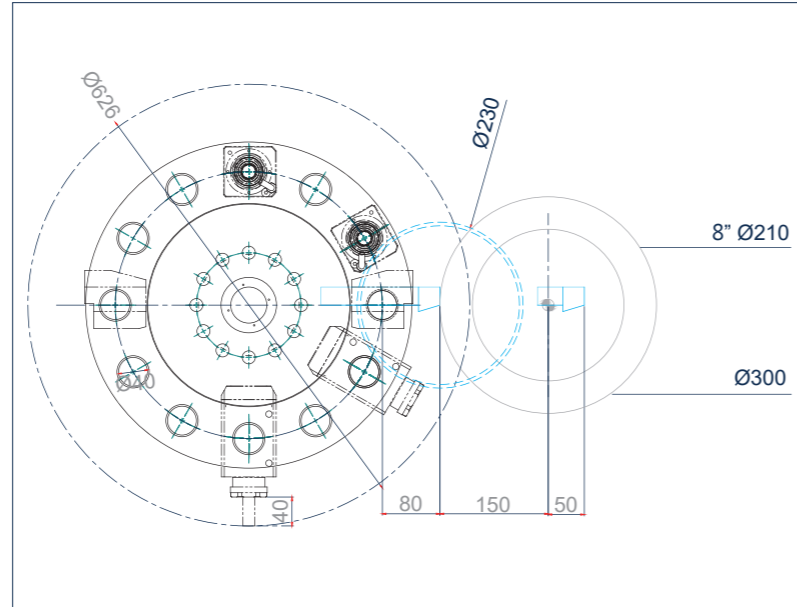

KT-25M

Max turning diameter 360 mm
 Max turning length 450 mm
 Chuck size 10"
 Tool capacity 12T

KT-25LM

Max turning diameter 360 mm
 Max turning length 700 mm
 Chuck size 10"
 Tool capacity 12T

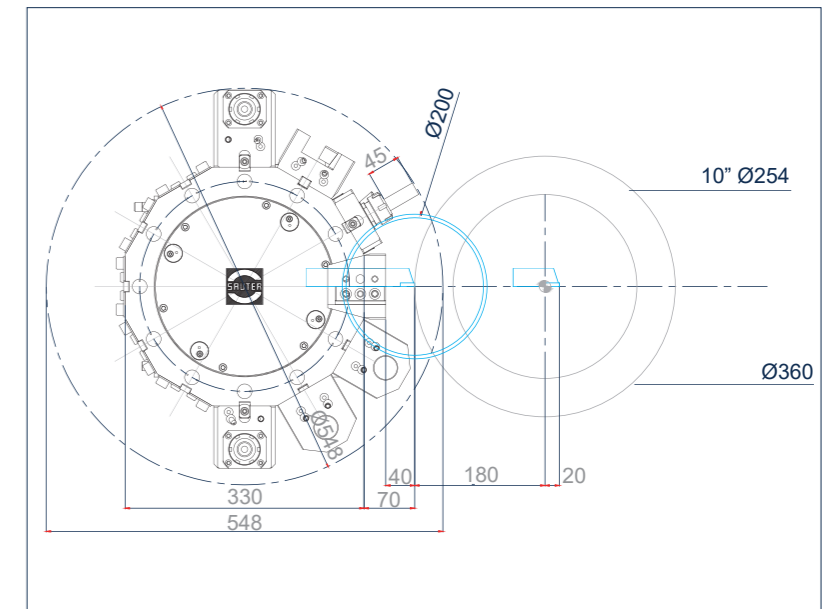
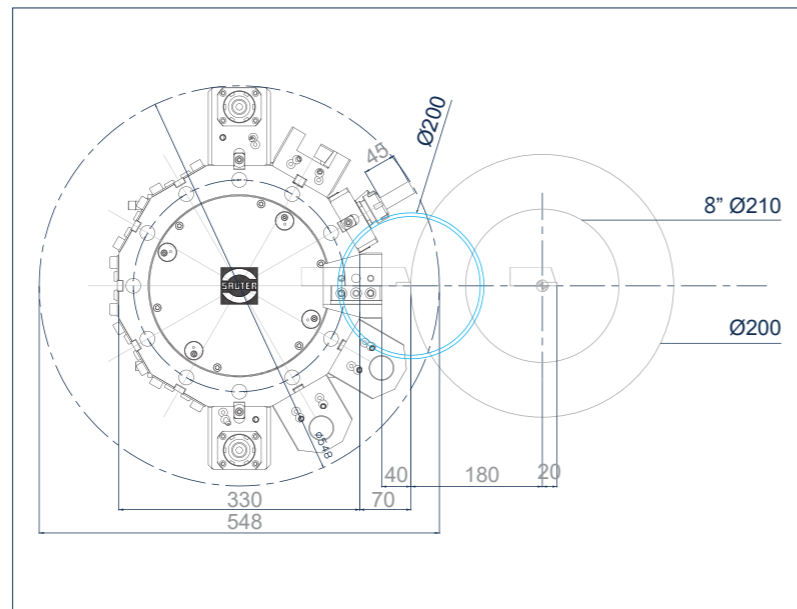
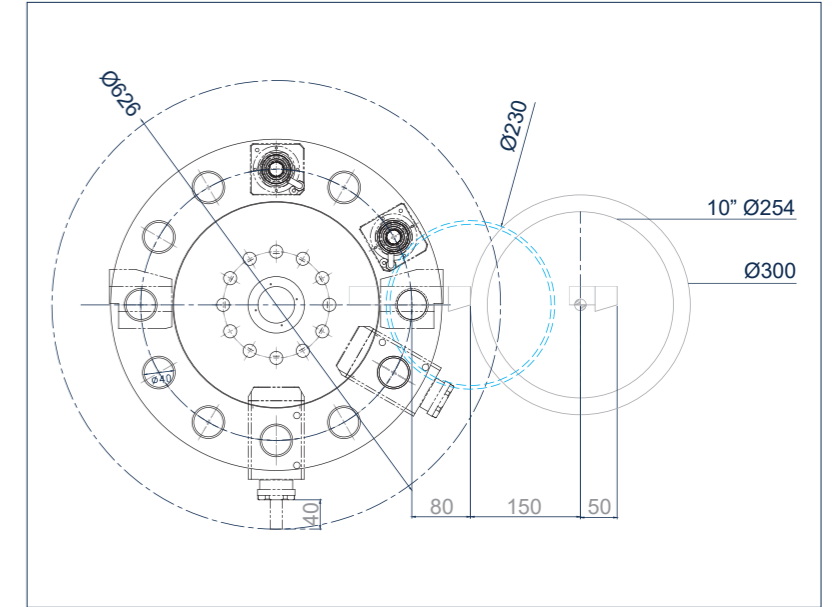

Feature

The KT turning machine series, equipped with Y-axis and spindle C-axis control, offers turning and milling (including polar interpolation and more) multitasking functions in a single step. The direct-driven servo motors on the X/Z/B-axis reduce backlash and vibration issues, resulting in improved production accuracy. This not only greatly reduces production time but also helps avoid spreading production errors across different machines. This turning series is particularly well-suited for the automobile, IT, and mold production industries.

Interior Structure

The one-piece casting slant bed design significantly enhances structural rigidity. Through the incorporation of a 30° slant bed design and a robust heavy-duty foundation, we have systematically optimized the overall machine structure's rigidity, specifically targeting improvements in the headstock, turret, and tailstock components.

Spindle

KT turning center series with spindle C-axis control and power turret combine the cutting, machining and drilling into one process. It not only greatly reduces the production time but eliminates the production errors created by having separate processes.

Hand-Scraping Technique

The hand-scraping procedure is applied to contacting surfaces throughout all guide way slides, headstock, turret, and tailstock. This ensures ultimate assembly precision, structural rigidity, and balanced loading distribution.

Ball Screw

All the models are equipped with high-class ball screws, ensuring high positioning accuracy. We employ a ball screw pretension design across all axes to effectively minimize the need for backlash compensation in the machine body. This results in exceptional repeatability and positioning accuracy.

Slideway

The TURCITE-B material is applied on both the X and Z slideways, firmly adhering it to prevent lubricant counter-flow and to facilitate seamless transmission. This ensures the consistent attainment of production accuracy requirements.

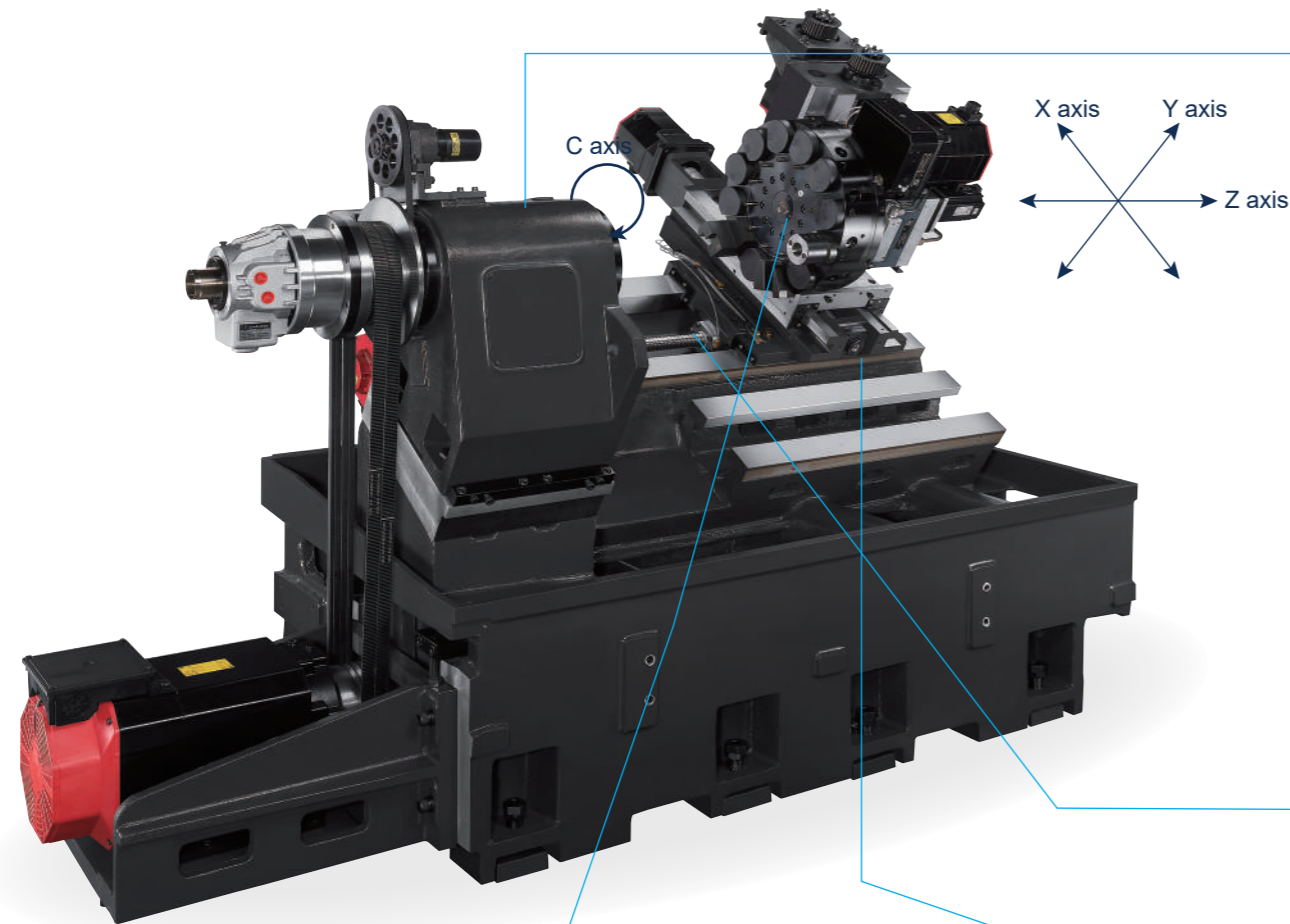

Power Turret

The turret is perfect for high-capacity turning machines, allowing both forward and reverse machining. The entire turn-mill series comes with all the modern features and functions of high-performance, high-capacity tool turrets. With a robust design and quick switching times, they excel in multi-duty manufacturing.



KT-20YM / YLM

Specification

ITEM	KT-20YM	KT-20YLM
Bed swing diameter	700 mm	700 mm
Saddle swing diameter	580 mm	580 mm
Max turning diameter	210 mm	210 mm
Max turning length	450 mm	700 mm
Bar capacity	52 mm	52 mm
Chuck size	8"	8"
Spindle motor	11/15 kw	11/15 kw
Spindle speed	4500 rpm	4500 rpm
Spindle nose	A2-6	A2-6
X-axis travel	180+15 mm	180+15 mm
Z-axis travel	450 mm	700 mm
Y-axis travel	+/-50 mm	+/-50 mm
X-axis rapid feed rate	24 m/min	24 m/min
Z-axis rapid feed rate	24 m/min	24 m/min
Y-axis rapid feed rate	20 m/min	20 m/min
Rail type	Box	Box
Tool capacity	VDI-40 12T	VDI-40 12T
Floor space (LxWxH)	3509x2007x2175 mm	3838x2007x2175 mm
Machine weight	5300 kg	5800 kg



KT-25YM / YLM

Specification

ITEM	KT-25YM	KT-25YLM
Bed swing diameter	700 mm	700 mm
Saddle swing diameter	580 mm	580 mm
Max turning diameter	210 mm	210 mm
Max turning length	450 mm	700 mm
Bar capacity	75 mm	75 mm
Chuck size	10"	10"
Spindle motor	15/18.5 kw	15/18.5 kw
Spindle speed	3500 rpm	3500 rpm
Spindle nose	A2-8	A2-8
X-axis travel	180+25 mm	180+25 mm
Z-axis travel	450 mm	700 mm
Y-axis travel	+/-50 mm	+/-50 mm
X-axis rapid feed rate	20 m/min	20 m/min
Z-axis rapid feed rate	20 m/min	20 m/min
Y-axis rapid feed rate	20 m/min	20 m/min
Rail type	Box	Box
Tool capacity	VDI-40 12T	VDI-40 12T
Floor space (LxWxH)	3509x2007x2175 mm	3838x2007x2175 mm
Machine weight	5500 kg	6000 kg

Cutter Interference

KT-20YM

Max turning diameter 210 mm
 Max turning length 450 mm
 Chuck size 8"
 Tool capacity 12T

KT-20YLM

Max turning diameter 210 mm
 Max turning length 700 mm
 Chuck size 8"
 Tool capacity 12T

KT-25YM

Max turning diameter 210 mm
 Max turning length 450 mm
 Chuck size 10"
 Tool capacity 12T

KT-25YLM

Max turning diameter 210 mm
 Max turning length 700 mm
 Chuck size 10"
 Tool capacity 12T

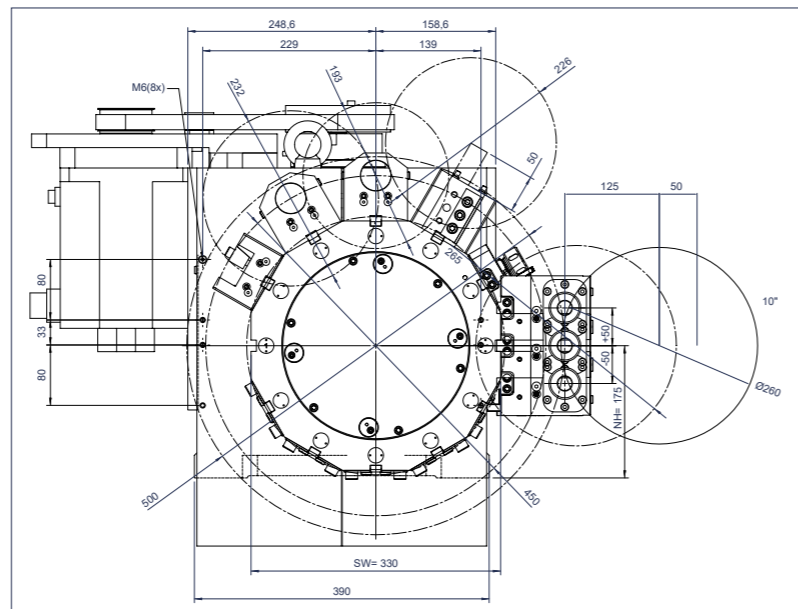
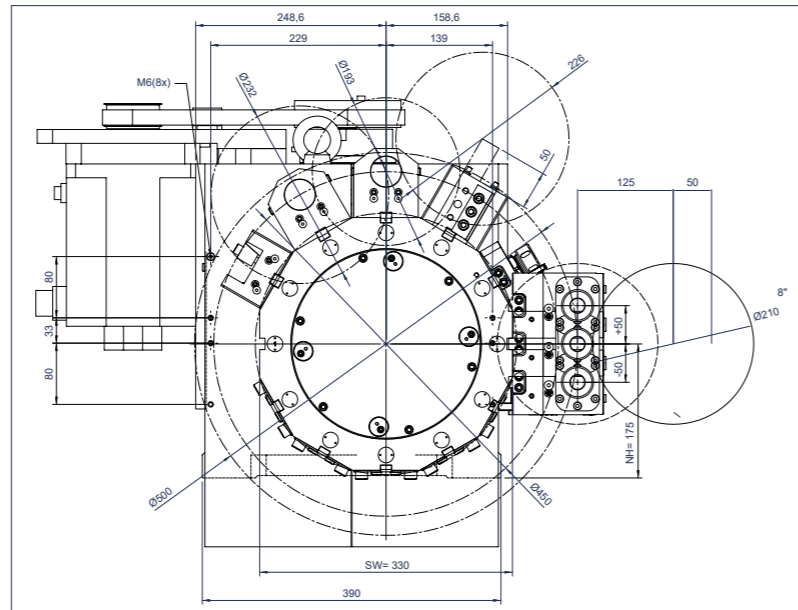

Y & C-axis Function

	Y-axis & C-axis	C-axis
End Face Drilling Fast		End Face Drilling Slow
OD Machining		OD Machining
Off-center Drilling		Off-center Drilling
Off-center Side Grooving		Off-center Side Grooving
Large Face Milling Fast		Large Face Milling Slow
Contouring Smooth		Contouring
Grooving Machining Higher Accuracy		Grooving Machining Lower Accuracy
Polar Interpolation Fast		Polar Interpolation Slow
Circular Interpolation Fast		Circular Interpolation Slow

Output & Torque

KT-20M

KT-20LM

β22

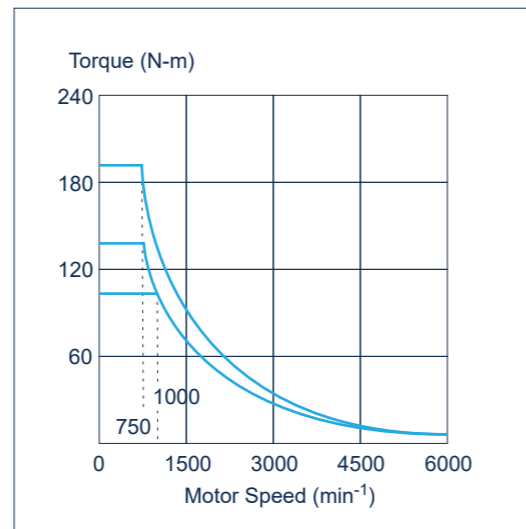
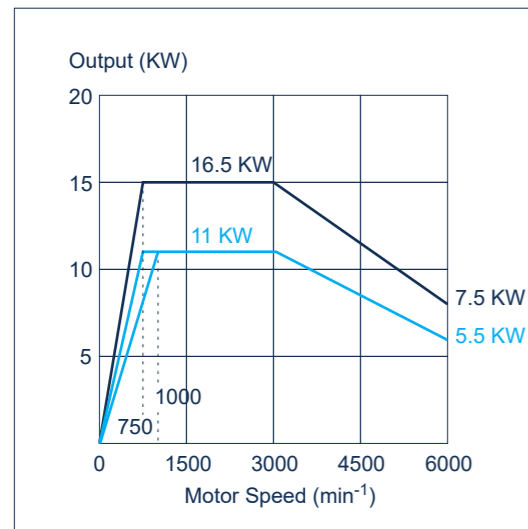

KT-25M

KT-25LM

β30

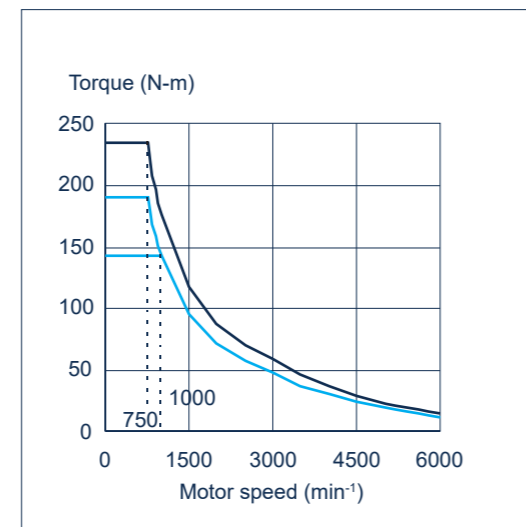
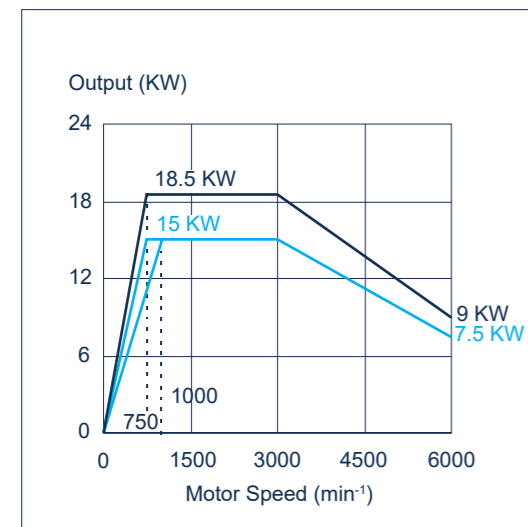

Floor Space

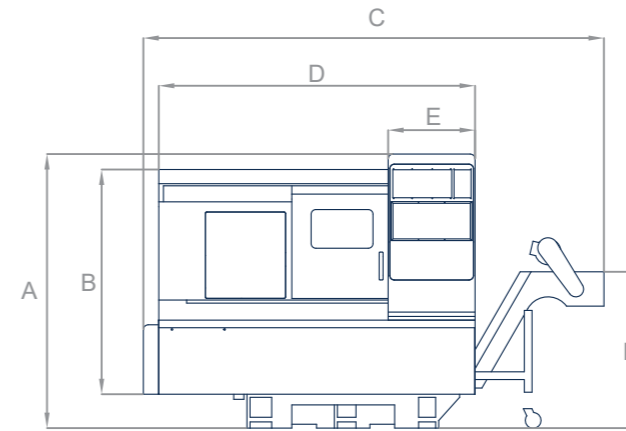

Front

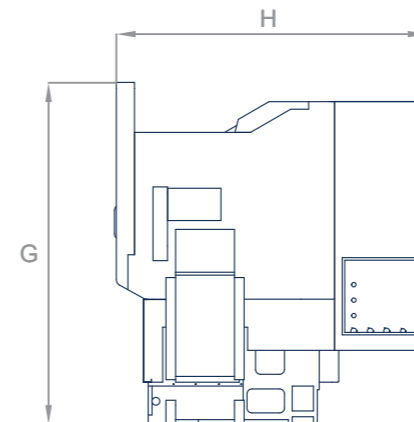

Side

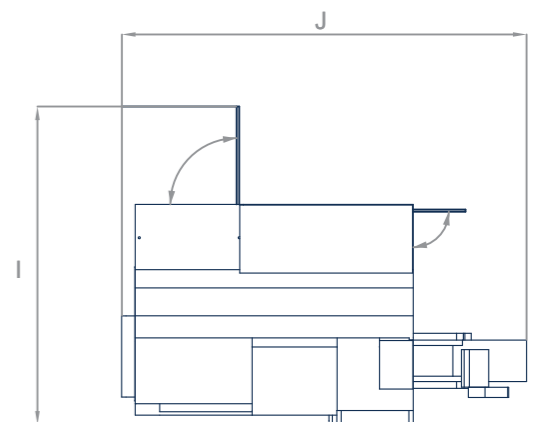

Top

Specification

ITEM	KT-20M	KT-20LM	KT-20YM	KT-25M	KT-25LM	KT-25YM
A	1867 mm	1907 mm	2174 mm	1867 mm	1907 mm	2174 mm
B	1655 mm	1657 mm	2077 mm	1655 mm	1657 mm	1957 mm
C	3509 mm	3838 mm	3509 mm	3509 mm	3838 mm	3509 mm
D	2526 mm	3006 mm	2417 mm	2526 mm	3006 mm	2417 mm
E	620 mm	620 mm	560 mm	620 mm	620 mm	560 mm
F	1012 mm	1032 mm	1032 mm	1012 mm	1032 mm	1032 mm
G	1867 mm	1907 mm	2174 mm	1867 mm	1907 mm	2174 mm
H	1660 mm	1692 mm	2007 mm	1660 mm	1692 mm	2007 mm
I	2372 mm	2404 mm	2736 mm	2372 mm	2404 mm	2719 mm
J	3509 mm	3838 mm	3509 mm	3509 mm	3838 mm	3509 mm

© KAIFENG MACHINERY CO., LTD. © RESERVES ALL THE RIGHTS TO AMEND ANY OF THE SPECIFICATION WITHOUT NOTICE.

ITEM	UNIT	KT-20M	KT-20LM	KT-20YM	KT-20YLM	KT-25M	KT-25LM	KT-25YM	KT-25YLM
Bed swing diameter	mm	530	530	700	700	530	530	700	530
Saddle swing diameter	mm	380	380	580	580	380	380	580	380
Maximum turning diameter	mm	360	360	210	210	360	360	210	210
Maximum turning length	mm	450	700	450	700	450	700	450	700
Bar capacity	mm	52	52	52	52	75	75	75	75
Power chuck diameter	inch	8	8	8	8	10	10	10	10
Spindle motor power	kw	11/15	11/15	11/15	11/15	15/18.5	15/18.5	15/18.5	15/18.5
Spindle speed	rpm	4500	4500	4500	4500	3500	3500	3500	3500
Spindle nose taper	-	A2-6	A2-6	A2-6	A2-6	A2-8	A2-8	A2-8	A2-8
Spindle bearing diameter	mm	100	100	100	100	120	120	120	120
Spindle taper	-	1/20	1/20	1/20	1/20	1/20	1/20	1/20	1/20
X/Z-axes servo motor	kw	3/3	3/3	3/3	3/3	3/3	3/3	3/3	3/3
X-axis travel	mm	180+20	180+20	180+15	180+15	180+30	180+30	180+25	180+25
Z-axis travel	mm	450	700	450	700	450	700	450	700
Y-axis travel	mm	---	---	+/-50	+/-50	---	---	+/-50	+/-50
X-axis rapid feed rate	m/min	24	24	24	24	20	20	20	20
Z-axis rapid feed rate	m/min	24	24	20	20	20	20	20	20
Y-axis rapid feed rate	m/min	---	---	20	20	---	---	20	20
Slideway type	sideway	Box	Box	Box	Box	Box	Box	Box	Box
X/Z-axes ballscrew/pitch	mm	32/36 (P8/P10)	32/36 (P8/P10)	32/36 (P8/P10)	32/36 (P8/P10)	32/36 (P8/P10)	32/36 (P8/P10)	32/36 (P8/P10)	32/36 (P8/P10)
X/Z-axes slideway width	mm	50/50/70/80	50/50/70/80	X50/Y58/Z70	X50/Y58/Z70	50/50/70/80	50/50/70/80	X50/Y58/Z70	X50/Y58/Z70
Turret driven type	-	Servo	Servo	Servo	Servo	Servo	Servo	Servo	Servo
Tool capacity	station	VDI-40 12T	VDI-40 12T	VDI-40 12T	VDI-40 12T	VDI-40 12T	VDI-40 12T	VDI-40 12T	VDI-40 12T
Tailstock travel positioning	-	Hydraulic	Hydraulic	Optional	Optional	Hydraulic	Hydraulic	Optional	Optional
Quill taper diameter	mm	70	70	70	70	85	85	85	85
Tailstock quill travel	mm	110	110	110	110	150	150	150	150
Tailstock base travel	mm	400	650	---	---	400	650	---	---
Quill taper size	MT	MT#4	MT#4	MT#4	MT#4	MT#5	MT#5	MT#5	MT#5
Hydraulic tank capacity	liter	60	60	60	60	60	60	60	60
Coolant tank capacity	liter	150	310	150	310	150	310	150	310
Floor space (LxWxH)	mm	3350x1848x1867	3750x1660x2150	3509x2007x2175	3838x2007x2175	3510x1848x1867	4070x1705x1844	3509x2007x2175	3838x2007x2175
Machine weight	kg	4500	5200	5300	5800	4700	5200	5500	6000

Standard Accessories

ITEM	
Fanuc controller with LCD display	LED work light
Part program storage size (2MB)	Three color warning work light
Registered program (1000)	Heat exchanger for electric cabinet
Automatic data backup	Advanced auto lubrication system
Cs-axis and disk break	Belt type chip conveyor and chip cart (right discharge)
Hydraulic hollow cylinder for chuck	Foot switch for chuck operation
Hydraulic 3-jaws chuck	Fully enclosed guarding
Standard soft jaws	Foundation leveling pads
Hydraulic power supply unit	Maintenance tool kit
Hydraulic tailstock	Operation & maintenance manuals
Coolant pump (5kg/cm ²)	2-years warranty on controller
Roll out coolant tank	1-year warranty on machine parts

Optional Accessories

ITEM	
Fanuc 0i-TF Plus Alpha (α22) spindle motor	Chuck air blow
Fanuc 0i-TF Plus Alpha (α30) spindle motor	Oil mist collector
Mitsubishi controller	Oil and water separator
Siemens controller	High pressure coolant pump
Syntec controller	Auto door
Hollow 2-jaw hydraulic chuck	Auto parts catcher
Hollow 3-jaw hydraulic chuck	Work-piece transport conveyor
Hollow 4-jaw hydraulic chuck	Bar feeder
Collet chuck	Auto parts loader/unloader (gantry style)
Programmable quill hydraulic tailstock	Door close start switch
Tailstock quill travel extension	A/C cooling system for electrical cabinet
Live center	Counter
Forming coil	Exterior control box
Keep-off rod	Regulator transformer
Tool presetter	